

Loading diagram

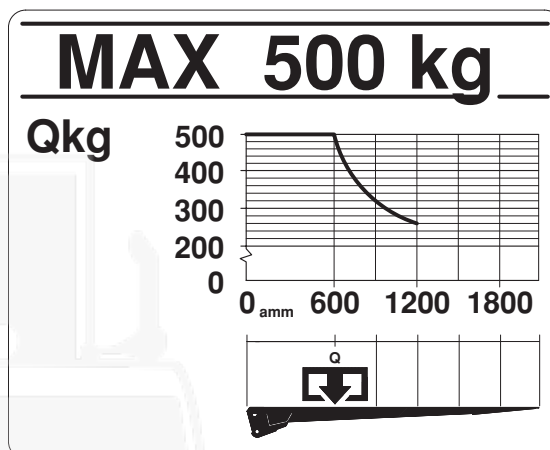

(190 bar)	12 volt	24 volt
Pump - Motor Unit	110 A	60 A
Magnet (hydraulic unit)	1,4 A	0,7 A
Magnet (electric safety valve)	1,5 A	0,75 A
Solenoid	1,8 A	0,9 A
Cable area:		
Control cable	1,5 mm <sup>2</sup>	1,5 mm <sup>2</sup>
Main cable 0-8 m	35 mm <sup>2</sup>	35 mm <sup>2</sup>
Main cable 8-15 m	35 mm <sup>2</sup>	35 mm <sup>2</sup>
Main cable <15 m	-	35 mm <sup>2</sup>
Power source:		
Min. capacity	140 Ah	110 Ah
Min. voltage	9 Volt	18 Volt

Installation dimensions (mm)

No cuts outs from the rear frame necessary

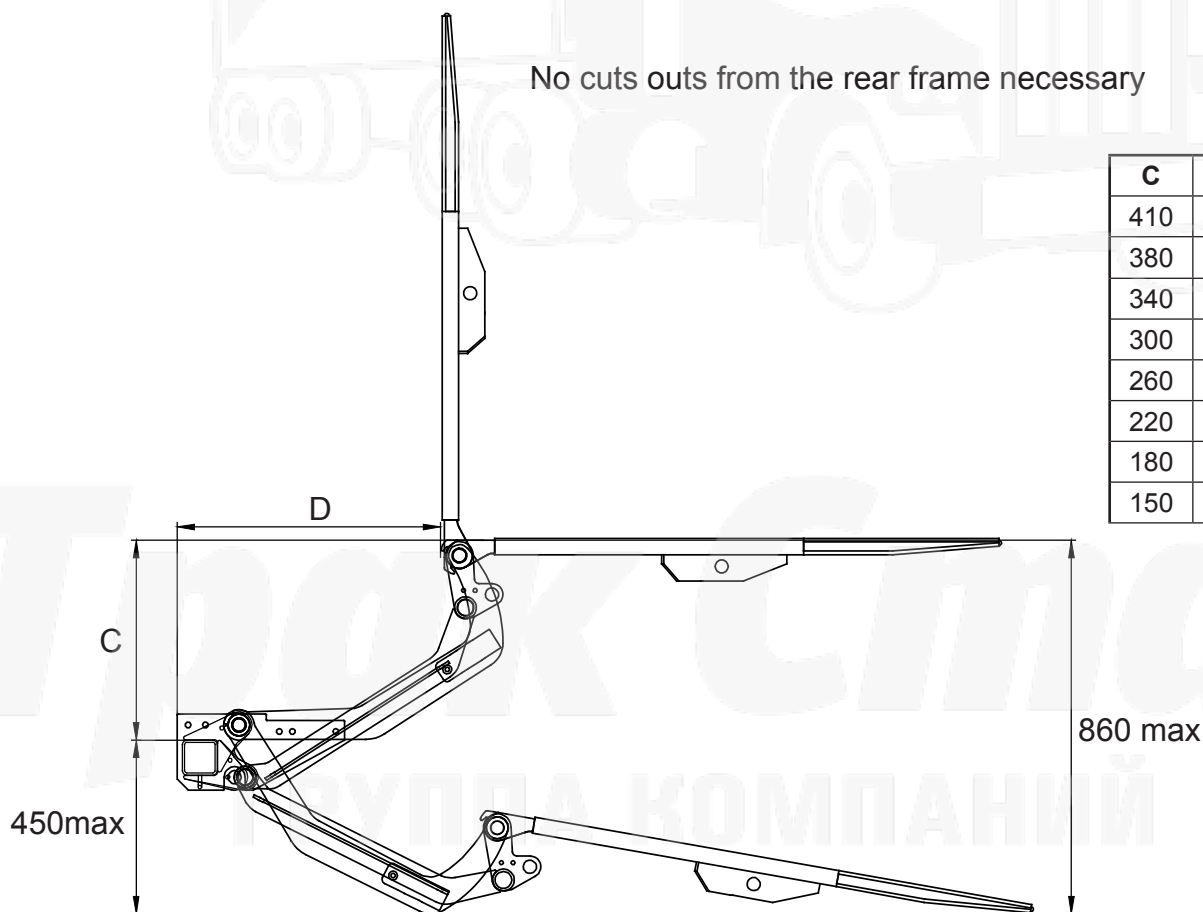

C	D
410	642
380	660
340	680
300	697
260	711
220	722
180	730
150	735

**ZEPRO**



**Трак Стар**  
ГРУППА КОМПАНИЙ