

| (150 bar) | 12 volt | 24 volt |
|--------------------------------|---------------------|---------------------|
| Pump - Motor Unit | 140 A | 75 A |
| Magnet (hydraulic unit) | 4,2 A | 2,1 A |
| Magnet (electric safety valve) | 1,5 A | 0,75 A |
| Solenoid | 1,5 A | 0,85 A |
| Cable area: | | |
| Control cable | 1,5 mm ² | 1,5 mm ² |
| Main cable 0-8m | 35 mm ² | 35 mm ² |
| Main cable 8-15m | 50 mm ² | 35 mm ² |
| Main cable <15m | - | 50 mm ² |
| Power source: | | |
| Min. capacity | 180 Ah | 170 Ah |
| Min. voltage | 9 Volt | 18 Volt |

Loading diagram

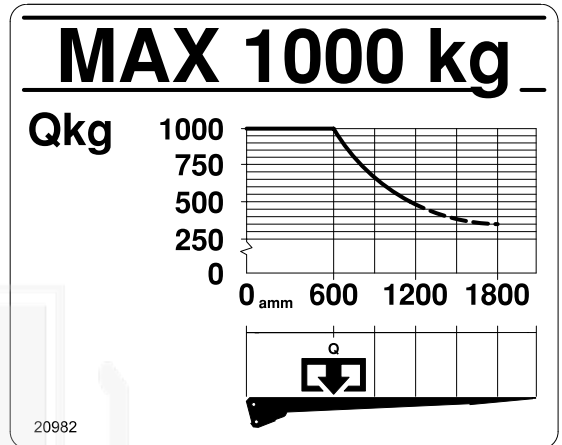

Installation dimensions (mm)

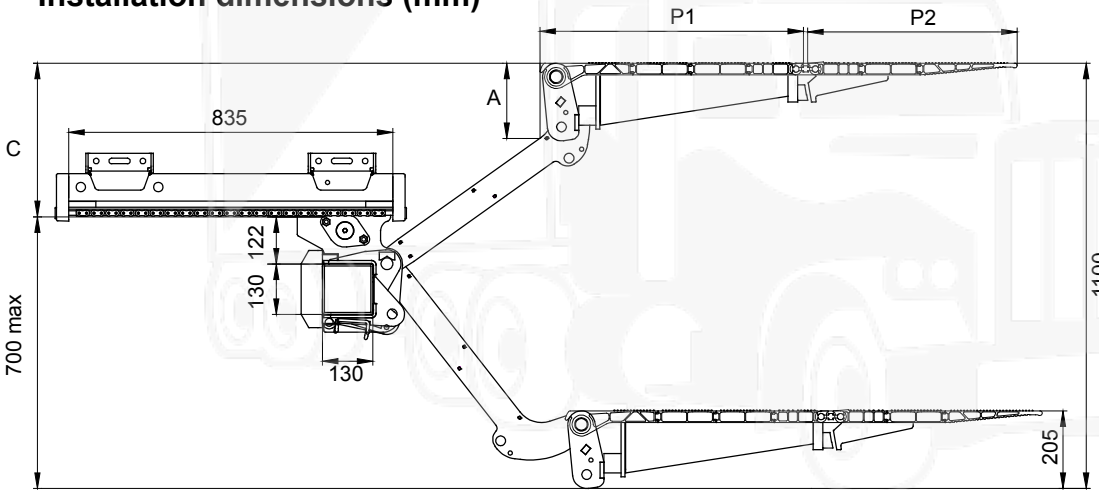

| A | C |
|-----|-----|
| 200 | 400 |
| 153 | 180 |

Double folding platform

| Platform length | P1 | P2 | Total overhang |
|-----------------|-----|-----|----------------|
| 1229 | 679 | 540 | 925 |

