

Loading diagram

(150 bar)	12 volt	24 volt
Pump - Motor Unit	140A	75A
Magnet (hydraulic unit)	4,2A	2,1A
Magnet (electric safety valve)	1,5A	0,75A
Solenoid	1,5A	0,85A
Cable area:		
Control cable	1,5mm ²	1,5mm ²
Main cable 0-8m	35mm ²	35mm ²
Main cable 8-15m	50mm ²	35mm ²
Main cable <15m	-	50mm ²
Power source:		
Min. capacity	180Ah	170Ah
Min. voltage	9 Volt	18 Volt

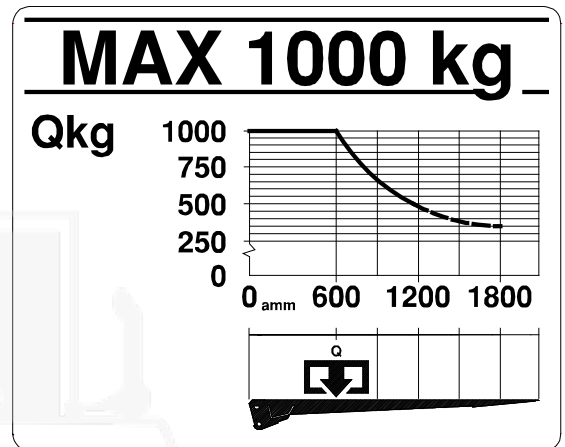

Installation dimensions (mm)

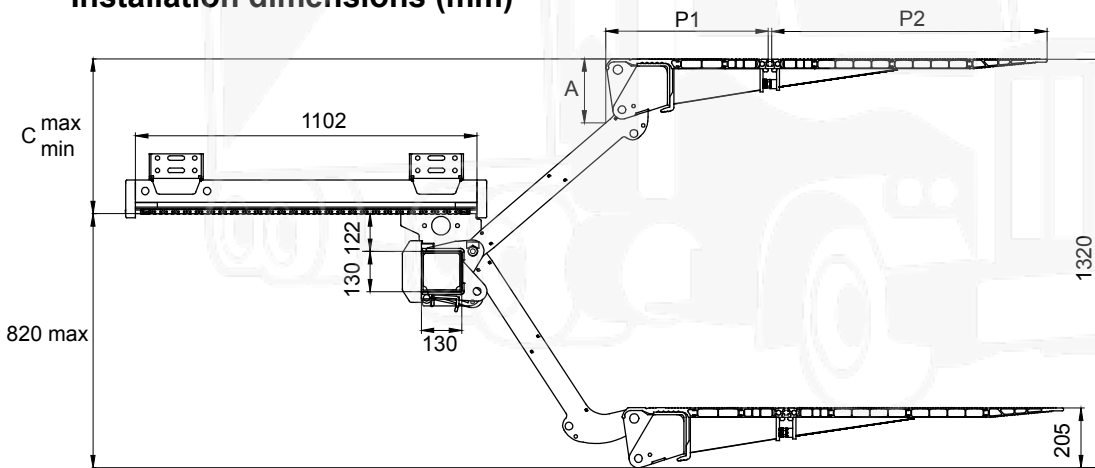

A	C
165	500
151	450
140	400
132	350
124	300
114	250

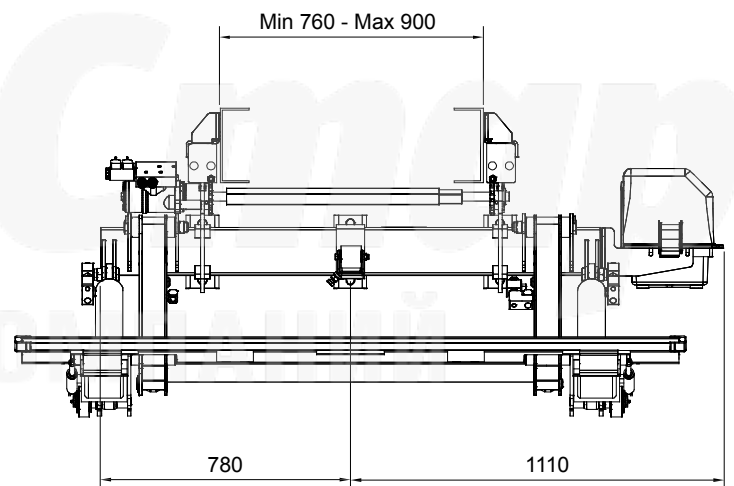
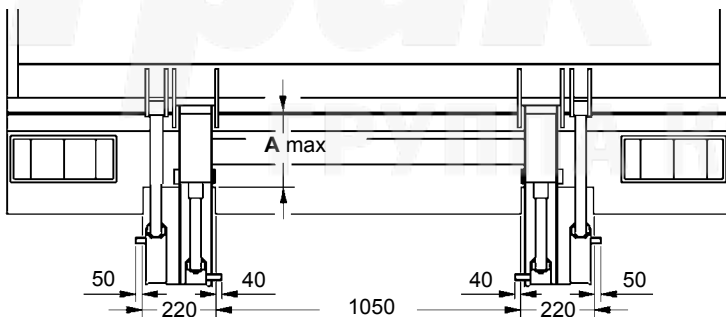
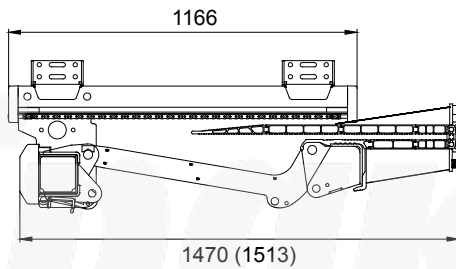

Single folding platform

Platform Length	P1	P2	Total overhang
1198	524	664	1470
1423	524	889	1470
1466	567	889	1513

