

Loading diagram

(150 bar)	12 volt	24 volt
Pump - Motor Unit	115 A	75 A
Magnet (hydraulic unit)	1,4 A	0,7 A
Magnet (electric safety valve)	1,5 A	0,75 A
Solenoid	1,8 A	0,9 A
Cable area:		
Control cable	1,5 mm <sup>2</sup>	1,5 mm <sup>2</sup>
Main cable 0-8m	35 mm <sup>2</sup>	35 mm <sup>2</sup>
Main cable 8-15m	35 mm <sup>2</sup>	35 mm <sup>2</sup>
Main cable <15m	-	35 mm <sup>2</sup>
Power source:		
Min. capacity	140 Ah	110 Ah
Min. voltage	9 Volt	18 Volt

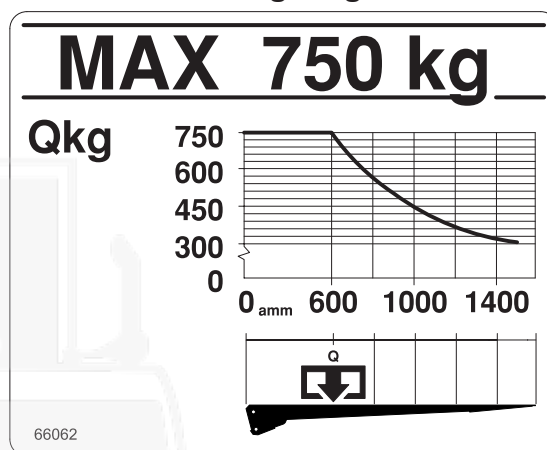

Installation dimensions (mm)

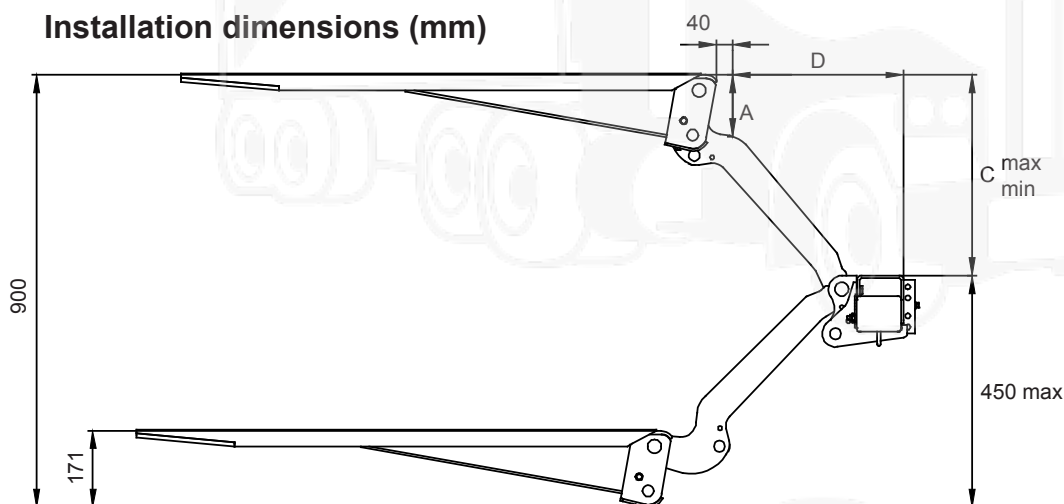

C	A	D
450	136	384
400	126	444
350	115	490
300	104	526
250	96	554

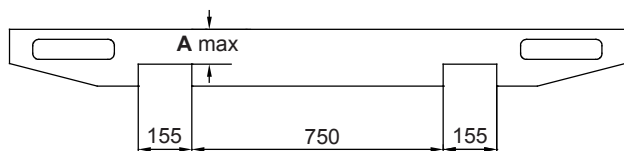
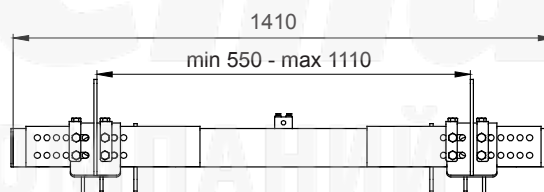
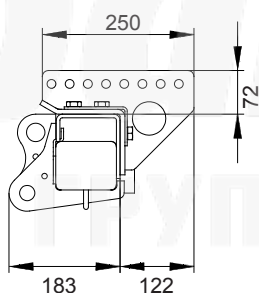

**ZEPRO**



**Трак Стар**  
ГРУППА КОМПАНИЙ

Телефон: +7 927 503 2024  
E-mail: ek225@truck-star.ru  
Сайт: www.truck-star.ru